

/ glider
loopy
take-off

design:
Gianantonio Perin
Giorgio Topan













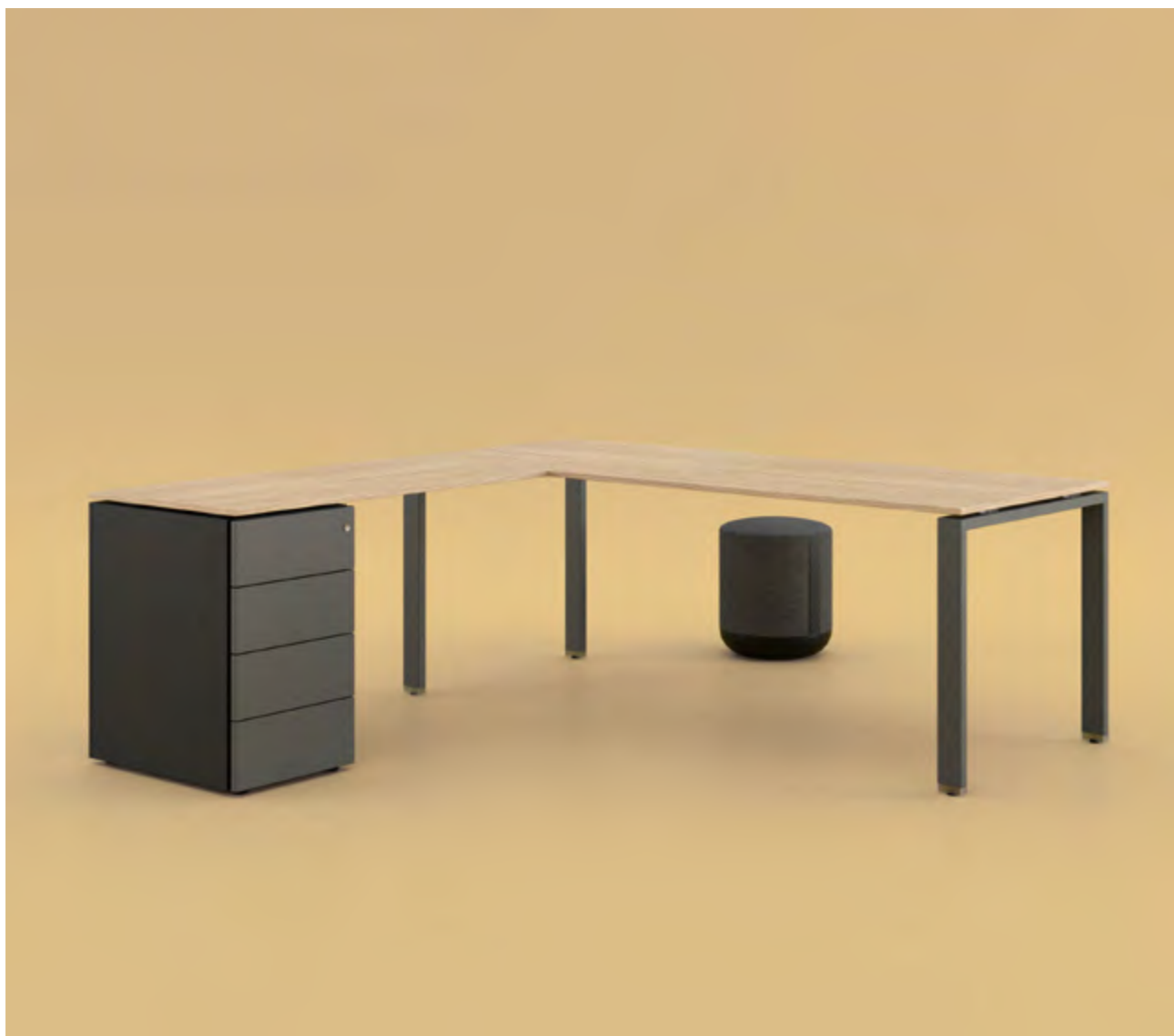





















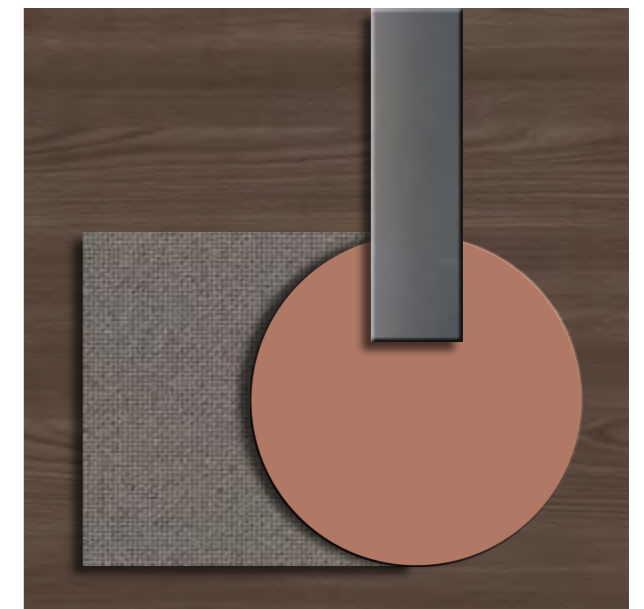
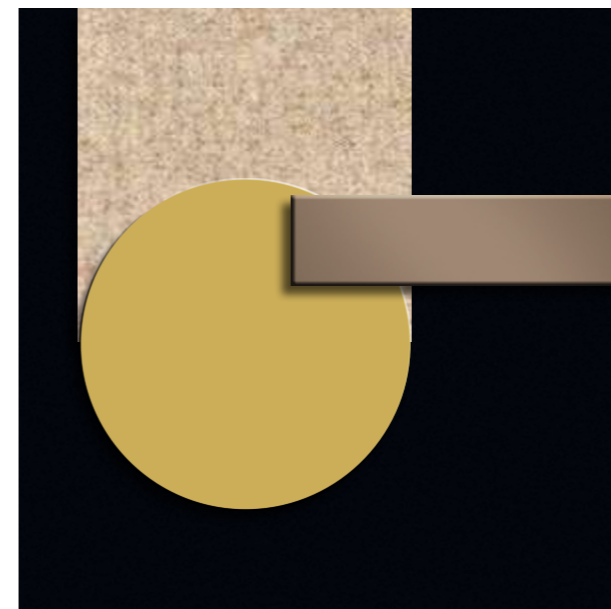
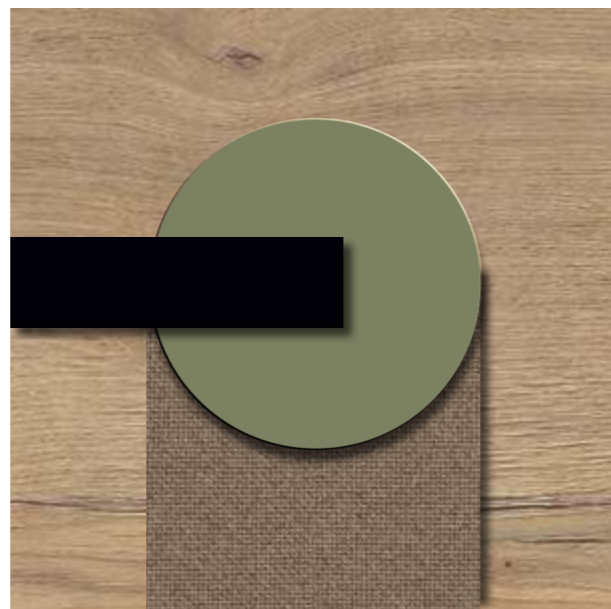
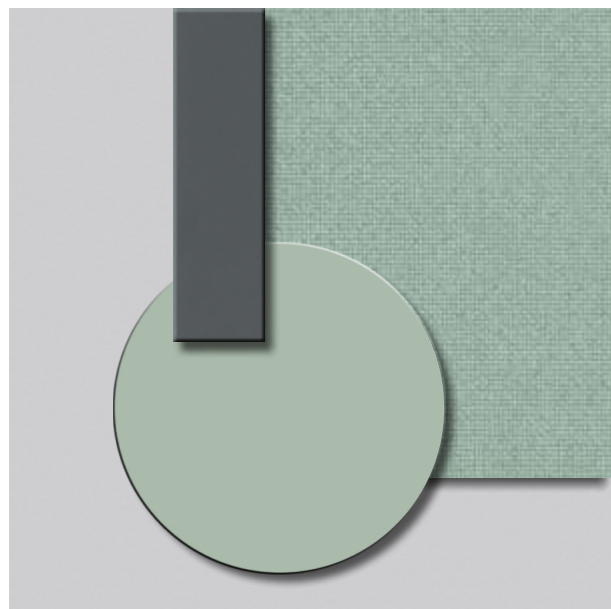
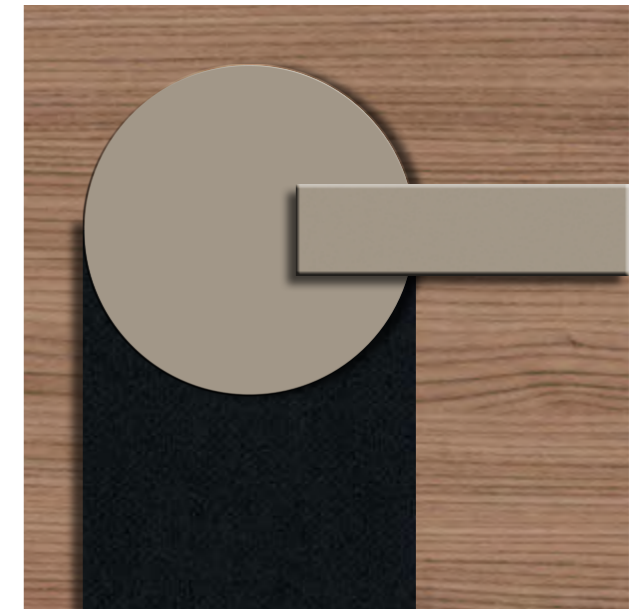
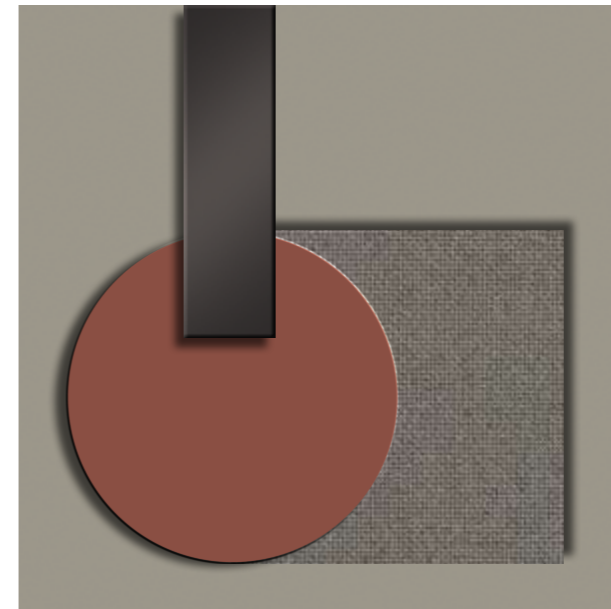
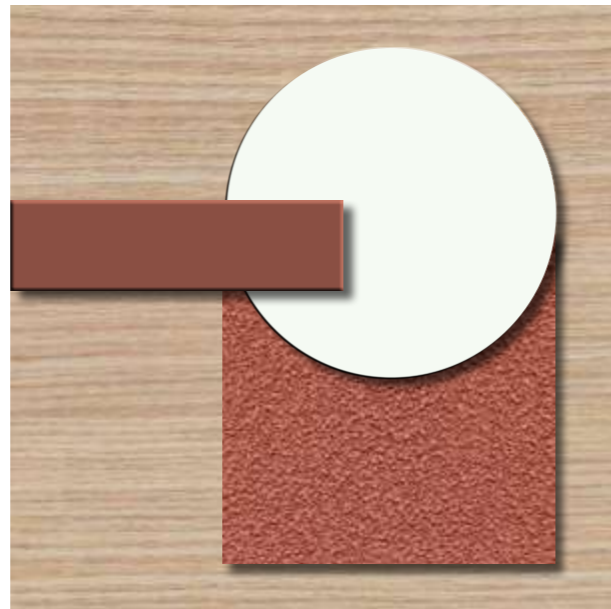
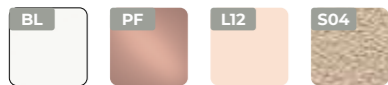
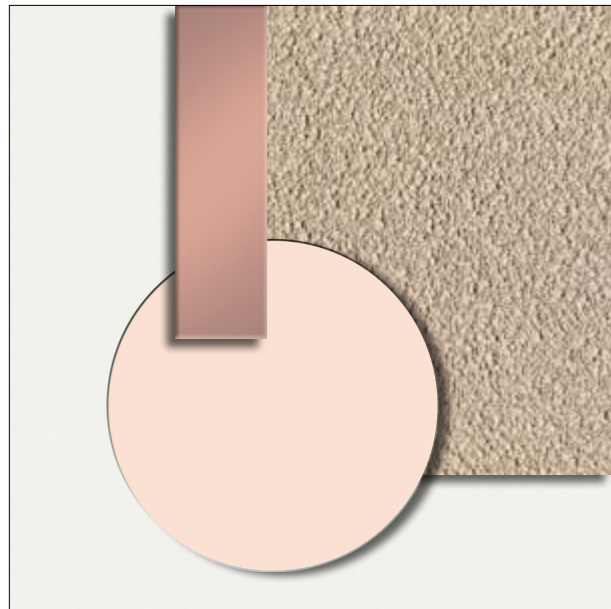



S 1,2 cm:
 w 100÷120 cm d 60 cm
 w 140÷200 cm d 80 cm
 w 200 cm d 100 cm
 w 124-240 cm d 124 cm

<p>h 74 d 60-80</p> <p>w 80÷200</p>	<p>h 74 d 100</p> <p>w 200</p>	<p>h 74 d 60-80</p> <p>w 80÷200</p>	<p>h 74 d 100</p> <p>w 200</p>
<p>h 74 d 80</p> <p>w 160÷200</p>	<p>h 74 d 100</p> <p>w 200</p>	<p>h 74 d 80</p> <p>w 160÷200</p>	<p>h 74 d 100</p> <p>w 200</p>
<p>h 74 d 60</p> <p>w 100-120</p>	<p>h 74 d 60-80</p> <p>w 120-200</p>	<p>h 74 d 80</p> <p>w 120÷200</p>	<p>h 74 d 60-80</p> <p>w 80÷120</p>
<p>h 74 d 124-164</p> <p>w 120÷200</p>	<p>h 74 d 124-164</p> <p>w 120÷200</p>	<p>h 74 d 124-164</p> <p>w 120÷200</p>	<p>h 74 d 60-80</p> <p>w 124-164</p>



<p>h 74 d 124-164</p> <p>w 100÷240</p>	<p>h 74 d 124-164</p> <p>w 280-320</p>	<p>h 74 d 240-320</p> <p>w 240-320</p>	<p>h 74 d 360-520</p> <p>w 360-520</p>
<p>h 74 ø 110-118</p>	<p>h 74 ø 118</p>	<p>h 74 ø 118-140-160</p>	<p>h 74 ø 118-140-160</p>
<p>h 38 d 60</p> <p>w 60-120</p>	<p>h 40 d 60</p>	<p>h 38 d 60</p>	<p>h 40 d 60</p>

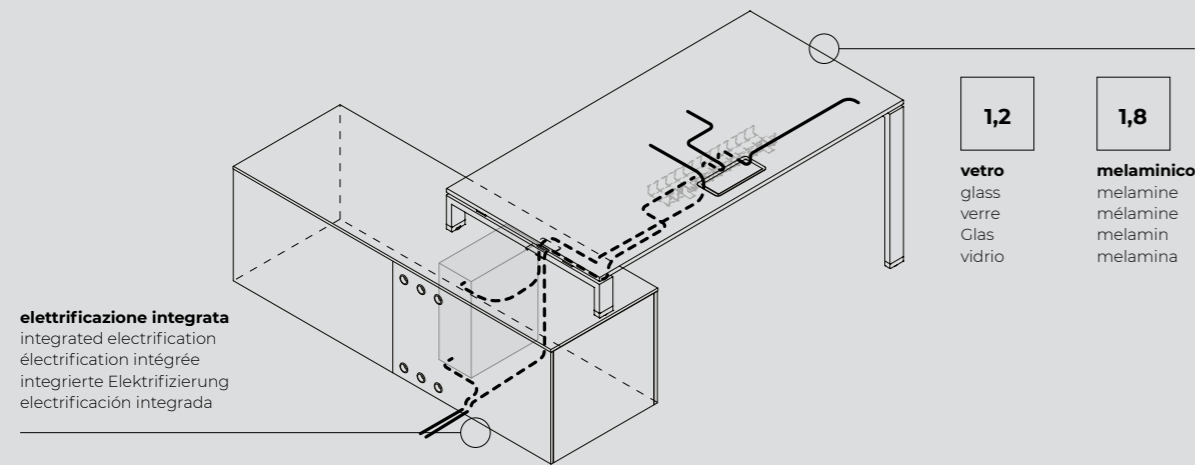
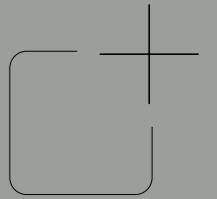

elettrificazione integrata
integrated electrification
électrification intégrée
integrierte Elektrifizierung
electrificación integrada

gambe
legs
piètements
Beine
patas

metallo, metal, métal, metal, metal

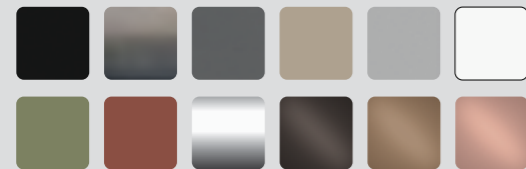

piano
worktop
plateau
tischplatte
plano

melaminico, melamine, mélamine, melamin, melamina



highlights



piedino regolabile
levelling foot
pied réglable
stellfuß
pie ajustable



accessori • accessoires • accessoires • Zubehör • accesorios

gonna
modesty panel
voile de fond
knieraumblende
faldón



ACCESSORI

accessories
accessories
Zubehör
accesorios

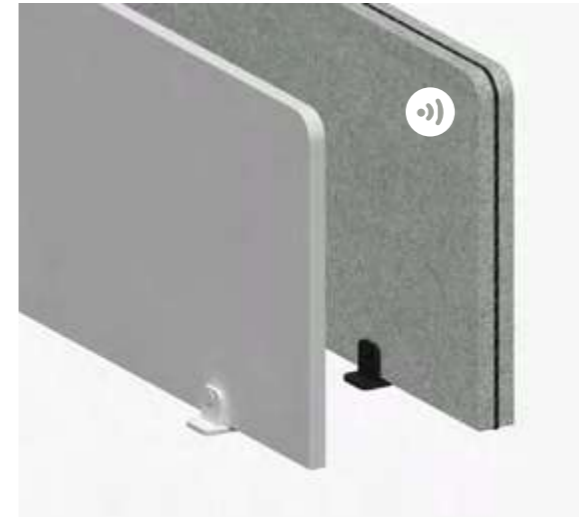



h 62 ÷ 86 cm

uno scatto ogni 2 cm
one step every 2 cm
une position chaque 2 cm
Eine Stelle alle 2 cm
una posició cada 2 cm

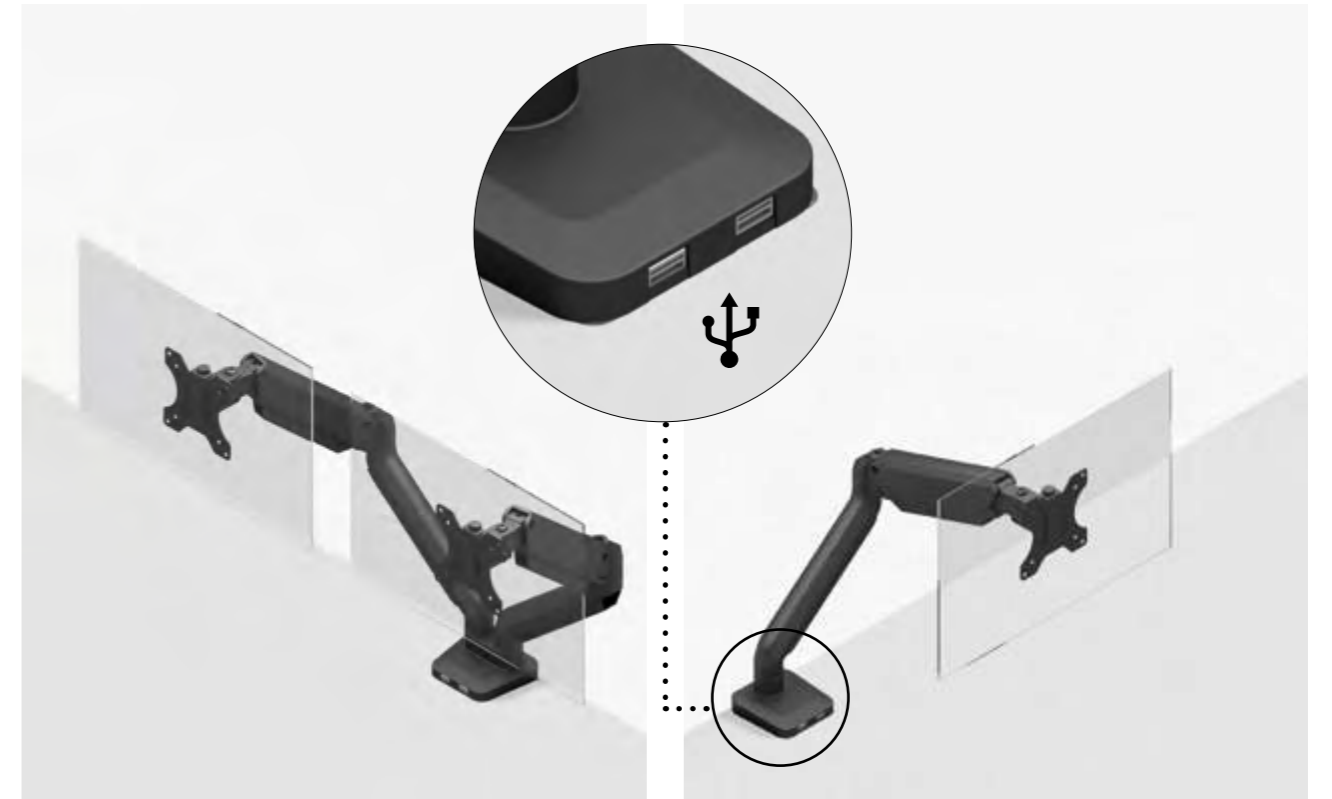

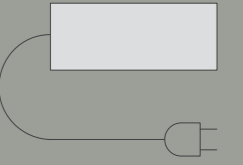

ELETTRIFICAZIONE
electrification
électrification
Elektrifizierung
electrificación



elettrificazione sopra piano, desktop electrification, électrification au-dessus du plateau, Elektrifizierung über den Tisch, electrificación encima de la tapa

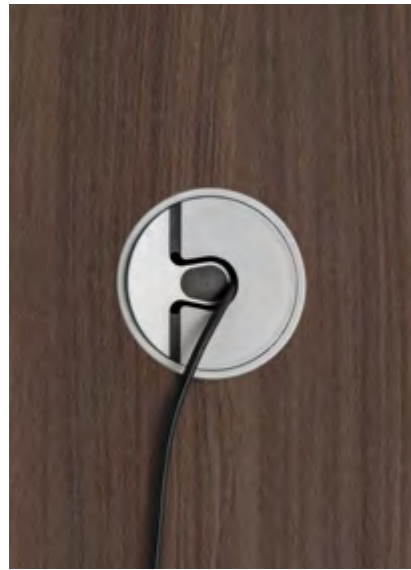

plastica, plastic, plastique, Plastick, plàstico



plastica, plastic, plastique, Plastick, plàstico



laccato opaco, lacquered matt, laqué mat
matt lackiert, lacado mate



metallo, metal, métal, metall, metal



metallo, metal, métal, metall, metal



plastica, plastic, plastique, Plastick, plàstico



plastica, plastic, plastique, Plastick, plàstico



laccato opaco, lacquered matt, laqué mat
matt lackiert, lacado mate



metallo, metal, métal, metall, metal



laccato opaco, lacquered matt, laqué mat
matt lackiert, lacado mate





eletrificazione sopra piano, desktop electrification, électrification au-dessus du plateau,
Elektrifizierung über den Tisch, electrificación encima de la tapa

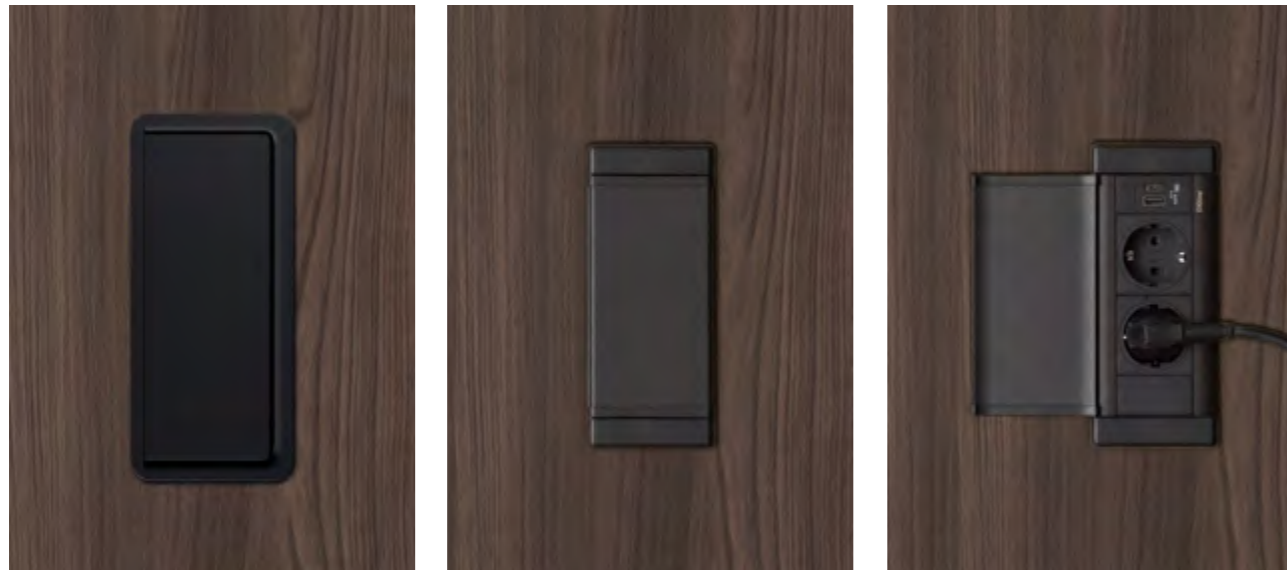

plastica, plastic, plastique, Plastick, plástico



laccato opaco, lacquered matt, laqué mat
matt lackiert, lacado mate



plastica, plastic, plastique, Plastik, plástico



eletrificazione sotto piano, under desktop electrification, électrification sous plateau,
Elektrifizierung unter den Tisch, electrificación debajo de la tapa



cestelli portacavi, cable holder baskets, paniers porte-câbles,
Kabelwanne, bandejas portacables



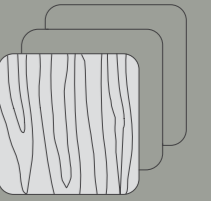

FINITURE E COLORI
finishing and colors
finitions et couleurs
Oberfläche und farben
acabados y colores



melaminico • melamine • mélamine • melamin • melamina

<p>MK</p>	<p>GS</p>	<p>GP</p>	<p>MO</p>
<p>nero black noir schwarz negro</p>	<p>grigio titanio titanium grey gris titane titangrau gris titanio</p>	<p>grigio perla pearl-grey gris perle perlgrau gris perla</p>	<p>tortora turtledove tourterelle taubengrau törtola</p>
<p>BL</p>	<p>NX</p>	<p>NC</p>	<p>RN</p>
<p>bianco white blanc weiß blanco</p>	<p>noce Lux walnut Lux noyer Lux lux Nussbaum nogal Lux</p>	<p>noce canaletto canaletto walnut noyer canaletto Canaletto Nussbaum nogal canaletto</p>	<p>rovere naturale natural oak chêne naturel Natur Eiche roble natural</p>
<p>RA</p>	<p>RA Superficie antibatterica Antibacterial surface Surface antibactérienne Antibakterielle Oberfläche Superficie antibacteriana</p>	<p>KK</p>	<p>KK Anti-touch</p>
<p>rovere anticato traditional oak chêne vieilli Eiche Antik roble antiguo</p>		<p>nero opaco matt black noir mat mattschwarz negro mate</p>	

metallo • metal • métal • metall • metal

<p>NF</p>	<p>FG</p>	<p>GF</p>	<p>TF</p>	<p>AF</p>	<p>BW</p>
<p>nero black noir schwarz negro</p>	<p>ferro grezzo raw steel métal brut rohes Metall hierro bruto</p>	<p>grigio titanio titanium grey gris titane titangrau gris titanio</p>	<p>tortora turtledove tourterelle taubengrau törtola</p>	<p>epox alluminio silver epoxy epoxy aluminium epoxy aluminium epoxidico aluminio</p>	<p>bianco white blanc weiß blanco</p>
<p>VF</p>	<p>CF</p>	<p>KR</p>	<p>BZ</p>	<p>EF</p>	<p>PF</p>
<p>oliva olive olive olive oliva</p>	<p>terracotta terracotta terre cuite terrakotta terracota</p>	<p>cromo lucido glossy chrome chromé brillant Chrom poliert cromo brillo</p>	<p>bronzo bronze bronze bronze bronce</p>	<p>grigio ombra shadow grey gris ombre vulcanschwarz sombra gris</p>	<p>rame rosa pink copper cuivre rose kupfer-Pink cobre rosa</p>

FG: La finitura ferro grezzo "FG" risalta la natura "industriale" del metallo grazie ad un trattamento protettivo trasparente. Differenze di tonalità, abrasioni, striature e saldature sono tipici della materia prima stessa e delle successive lavorazioni e sono tra gli elementi caratterizzanti del prodotto e per questo non contestabili.
FG: The raw steel finish "FG" emphasizes the "industrial" nature of the metal thanks to a transparent protective treatment. Differences in shades, abrasions, stripes and welds are typical of the raw material and subsequent processes, and are among the characteristic elements of the product, therefore not claimable.
FG: La finition en métal brut "FG" démarque la nature "industrielle" du Métal grâce à un traitement avec une protection transparente. Les différences dans les nuances, les abrasions et les soudures sont typiques de la matière première et des ultérieures process de production et font partie des éléments caractéristiques du produit et donc non contestables.
FG: Das rohes Metall-Finish "FG" sticht besonders hervor der "Industriellen" Natur der Metall durch einer Transparenten Schutz Behandlung. Unterschiede in Farbton, Abrieb, Streifen und Schweissungen sind typisch für den Rohstoff und die nachfolgenden Prozesse und gehören zu den charakteristischen Elementen des Produkts und daher sind nicht anfechtbar.
FG: El acabado de hierro bruto "FG" destaca la naturaleza "industrial" del Metal gracias a un tratamiento protector transparente. Las diferencias en los tonos, abrasiones, rayas y soldaduras son típicas de la materia prima y los procesos posteriores y se encuentran entre los elementos característicos del producto y, por lo tanto, es indiscutible.

Bralco Srl
Via Luigi Einaudi, 1
31058 Susegana (TV) Italy

T +39 0438 43 77
info@bralco.it
bralco.it

follow us on:



project: gherardi architetti
images: studio emozioni, virtual design
printed: grafiche antiga
09_2025

Thanks to:
Anastasiades, Davide Groppi, Lym



Particolari tecnici ed estetici possono essere modificati senza preavviso.
Le rese cromatiche non sono vincolanti così come la fedeltà della riproduzione.
Dati, misure e dettagli devono essere verificati con il listino.

Technical and aesthetic details can be modified without notice.
Colour rendering may differ.
Check the data, measures and details on the price list.

Les détails techniques et esthétiques peuvent être modifiés sans préavis.
Le rendu chromatique n'est pas contractuel, ainsi que la fidélité de la reproduction.
Les données, les mesures et les détails doivent être vérifiés avec le tarif.

Technische und ästhetische Details könnten ohne Voranmeldung geändert werden.
Die Echtheit der Farbwiedergabe ist nicht verbindlich.
Daten, Maße und Details sind in der Preisliste zu überprüfen.

Los detalles técnicos y estéticos pueden ser modificados sin preaviso.
Los rendimientos de color y la fidelidad de la reproducción no son vinculantes.
Los datos, las medidas y los detalles deben ser verificados con la tarifa de precios.

